

## Oil Pan

### Material

Item	Specification
Motorcraft® SAE 5W-30 Premium Synthetic Blend Motor Oil XO-5W30-QSP (US); Motorcraft® SAE 5W-30 Super Premium Motor Oil CXO-5W30-LSP12 (Canada); or equivalent	WSS-M2C929-A

### Removal and Installation

**NOTICE:** During engine repair procedures, cleanliness is extremely important. Any foreign material, including any material created while cleaning gasket surfaces that enters the oil passages, coolant passages or the oil pan, can cause engine failure.

1. With the vehicle in NEUTRAL, position it on a hoist. For additional information, refer to [Section 100-02](#).
2. Remove the bolt and detach the Power Steering Pressure (PSP) tube bracket from the crossmember.
  - To install, tighten to 11 Nm (97 lb-in).

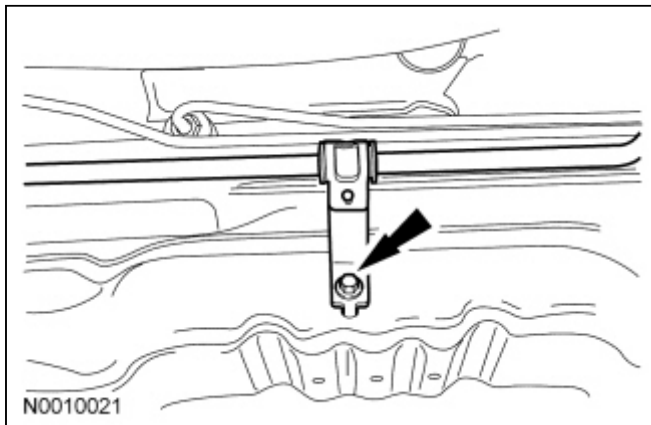

3. Remove the 2 power steering gear bolts and position aside the steering gear.
  - To install tighten to 115 Nm (85 lb-ft).

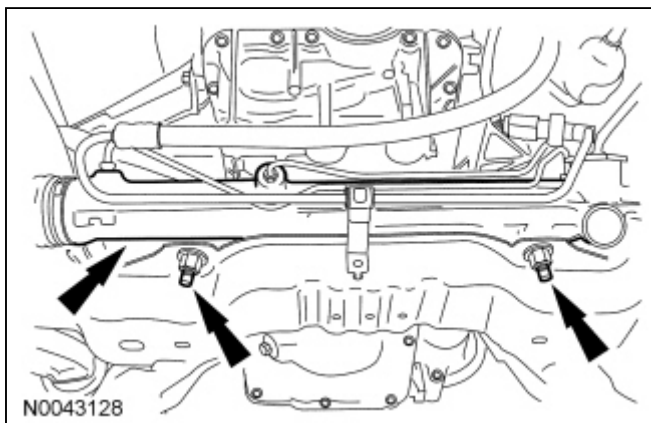

4. Remove the oil drain plug and drain the engine oil.

- To install, tighten to 26 Nm (19 lb-ft).
5. Remove the bolts, the oil pan and the gasket. Discard the gasket.
    - To install, tighten to 11 Nm (97 lb-in).
  6. **NOTICE: Do not use metal scrapers, wire brushes, power abrasive discs or other abrasive means to clean sealing surfaces. These tools cause scratches and gouges which make leak paths.**

Clean and inspect the sealing surfaces.

7. To install, reverse the removal procedure.
  8. Fill the engine with clean engine oil.
-